



Application of DI-NOC™ Films

A Guide for Interior and Exterior Dry Applications

DI-NOC™ is designed for interior/exterior decoration of high class decorative walls, ceilings, elevators, doors, floors, outside furniture, glass, wet areas (kitchens, bath rooms, laundries etc.). The application of DI-NOC™ is very simple, leading to a superb finish. Due to the Comply™ adhesive feature, air bubbles escape during application. Excellent adhesion and flexibility allows application to many complex curved substrates and for refurbishments.

Typical DI-NOC™ Applications

- For walls, ceilings, entrance halls, passage ways, doors, department stores, conference rooms, banks, offices, elevators, hospitals, exits, bathrooms, restaurants, lobbies, interior of trains and ships DI-NOC™ Wood Grain, DI-NOC™ Fine Wood or DI-NOC™ 21 is recommended. All DI-NOC films, besides DI-NOC Floor, are suitable for these applications
- Shop floors: DI-NOC™ Floor Medallion
- Outdoors: ☀️ All DI-NOC™ films marked with a sun symbol
- Wet areas such as bathrooms and indoor pools, Neox, D Span Wood Grain

Table of Contents

Primer

Primer Recommendation 3

About DI-NOC™

DI-NOC™ Adhesion Characteristics 4

DI-NOC™ Processing Considerations 4

Effect of Overlamine on Adhesion 4

Symbols 4

About Walls, Floors Substrates

Wall Textures 4

Determining Type of Texture 4

Identifying Wall Composition 5

About Wall Texture Images 5

Inspecting and Repairing Walls 6

Common Interior Wall Problems 6

Outgassing

Application – General

Applying DI-NOC™ to Interior Walls/Floors 6

Who Can Install DI-NOC™ Films? 6

Tools and Supplies 6

Substrate Cleaning and Preparation 6

Wet or Dry Application Method? 7

Application Technique 7

Hinge Application Method 7

Butt Joint Method 8

Trimming Requirements 8

Finishing the Graphic Edges 8

Illustrated Application Methods

DI-NOC™ Application Procedure on 3-D Surfaces 9

Ceiling Application 9

Wall Paneling Application 10

Bathroom Application 10

Surface Patterns and Emboss Texture 10

Other Application Issues 10

Maintenance of DI-NOC™

Cleaning, Repair and Removal 10

DI-NOC™ Specifications 11

Miscellaneous

Warranty 11

3M Related Literature 11

DI-NOC™ Film Pre-Installation Worksheet

The Worksheet and Checklist are tools for you and your 3M sales representative to:

- summarize the type of DI-NOC™ you will be applying.
- review and understand the key factors required for a successful interior DI-NOC™ Film application.

Describe wall/floor texture *Check only one.*

- SMOOTH: Little or no surface variation.
- UNSMOOTH TEXTURE: Has high spots and low spots.
 - Medium: Relatively equal distribution of moderately high and low spots.
 - Heavy: Irregular and severe high spots and/or low spots.
- Others: Brick, concrete block, stucco and tile.

DI-NOC™ exposure conditions

Check all that apply.

- Constant temperature and humidity
- Temperature changes
- Direct sunlight
- Heating or cooling ducts in close proximity
- People can/will be able to touch it

Wall Surface Texture vs adhesion

- A smooth surface texture provides good adhesion
- Surfaces which are porous should be treated with care, adhesion may decrease over time if the surface is not properly prepared before application.
- Too much surface texture allows the adhesive only to adhere to the high points of the texture, which does not provide sufficient adhesion for a good application.
- DI-NOC™ laminated with a stiff overlamine, such as a slit-resistant overlamine or anti-graffiti film, cannot conform to any textures and must not be used.

Wall Surface Preparation and Painting

- Repair any existing wall damage (holes, loose wallboard joints, chipped or peeling paint) with putty to return it to like new condition.
- Use grit 100 sandpaper to smoothen the surface.
- Clean the wall prior to priming and painting.
- Paint the wall with a quality, semi gloss top coat. Do not use matte paint or paint with silicone, graffiti-resistant or texturizing additives.
- Prime the wall with a primer that is compatible with the top paint coat. Two coats may be required. Refer to DI-NOC™ recommended primers such as DP-900N, WP2000, etc.
- Allow the putty and primer to dry/cure as recommended by the primer/putty manufacturer.
- Do not apply DI-NOC™ to any wall that does not have excellent adhesion to substrate bonding. Do not apply to wallpaper.

DI-NOC™ Application

- Clean the wall immediately prior to applying DI-NOC™ Films.
 - For newly painted walls, use a soft, clean, lint-free cloth to thoroughly remove all dust.
 - For existing walls, wash with 1 teaspoon of synthetic detergent per liter of lukewarm water. Avoid soaps or preparations that contain waxes, oils, lotions or conditioners. Allow to dry thoroughly (at least one hour) before proceeding.
- Use a DRY application method.
- 3M™ Plastic Applicator PA1 (gold).
- Use straight overlapping strokes and use the rivetbrush and heat gun to push the DI-NOC™ adhesive into the texture of the wall to ensure good adhesion.
- Trim DI-NOC™ 5 mm from inner and outer wall corners.
- ALWAYS finish the graphic by working the squeegee/rivetbrush in small circles around the entire outer 5 cm of the graphic.

Primer Recommendations for DI-NOC™

Key to success:

Choosing and using the right primer and paint can have a significant affect on DI-NOC™ adhesion.

The goal is to achieve a good bond between the substrate, primer and DI-NOC™ films. Primer is required at any overlap and end / edge of the film. I.e. underneath the butt joint and wherever the material is stretched

SURFACE PREPARATION	SUBSTRATE						
	Wood Luan Veneer Chinese Veneer Hardboard	Plaster Board Calcium Silicate Board (with sealer coating) Asbestos Slate	PVC Coated Steel DI-NOC™ applied over DI-NOC™	Mortar (with sealer coating)	Bonderized Steel Plate Baked Enamel Paint on Steel	Aluminum Plate Stainless Steel	Plywood, MDF board Painted or coated metals, etc.
PRIMER	DP-900N*	WP-2000, DP-900N*	DP-900N*	DP-900N*	DP-900N*	WP-3000	
	Whole Surface			Edge or critical area of surface only			

Wait 15 - 30 minutes for drying primers before applying DI-NOC™. However, if the application surface temperature is below 10°C, you will need to wait 2 - 3 hours after applying primer.

Priming of DI-NOC™ Film

	Solvent Based Primers	Water Based Primers	
	DP-900N*	WP-2000	WP-3000
Type	Polyurethane based	Synthetic Rubber	Synthetic Rubber
Substrate Features	Refer above	Calcium Silicate and Plaster boards	Complex surfaces only
Container Size	1 liter	4 liter	120 ml
Usage	Do not dilute	Mix with maximum 4 parts water	Mix with maximum 4 parts water
Coverage	20 – 30 sqm/l	15 – 30 sqm/l	1.2 sqm/container
Color	Slightly Yellow (will go brown if exposed to UV)	Blue	Milky
Solids	13%	48%	40%
Viscosity	4.5 m Pa.s	2400 m Pa.s	500 m Pa.s
Shelf Life	Use within 1 year of purchase	Use within 1 year of purchase	Use within 1 year of purchase

* Alternatively you may use primer 3M™ Scotchmount™ 4297 (3M Automotive Division)

The use of primer causes a significant increase in adhesion force. Therefore repositioning of the film during application will be difficult and can even cause damage to the substrate below the primer. 3M holds no responsibility or liability in case of damage to the substrate. During pre-application inspection of the substrate this has to be taken into consideration so the proper precautions can be taken.

DI-NOC™ Adhesion Characteristics

Adhesion is the ability of the DI-NOC™ adhesives to bond to the substrate. The amount of both initial and final adhesion varies with the type of adhesive used on the DI-NOC™, the substrate/surface, and the application temperature and application techniques. The bond builds with time. DI-NOC™ may never achieve its full bond if the graphic is poorly applied or you are using the wrong DI-NOC™ series for the substrate.

- **Final Adhesion.** The maximum bond of a DI-NOC™ film is achieved in 24 to 48 hours after application.
- **Initial Adhesion.** The amount of bond needed to hold the graphic in place during application.
- **Size of Graphic.** The larger the DI-NOC™ graphic, the greater the adhesive bond to the wall must be to support the weight of the graphic.

DI-NOC™ Stretching. DI-NOC™ stretched during application may later shrink. This decreases wall adhesion and the graphic may fall off prematurely. Use primer to minimize shrinkage.

Film Processing Considerations

The common methods for processing large format DI-NOC™ include screen printing 1900 inks and 1920 DR clear, digital printing (DI-NOC™ 21 D-3000 Series is for Scotchprint™ system) PIJ with 3M™ 1920 DR or 3M™ 8519/8520 laminate and electrocut (multi color production is not recommended).

Processing methods and conditions may affect the DI-NOC™ application and performance. Always refer to the DI-NOC™ Product Bulletin for details.

Effect of Overlamine on Adhesion

Finished graphics must retain some flexibility in order to achieve maximum adhesion. If a laminate is required, use the recommended DI-NOC™ laminate. Do not use a stiff or thick overlamine on the graphic, such as 3M's Scotchgard™ Graphic and Surface Protection Film 8991. If abrasion resistance is required, use DPF-100 or DPF-200 laminate.

Note: Only DI-NOC™ with smooth surfaces can be used for printing. If the surface pattern is rough, inks will not adhere properly.

Symbols

- ☀ Suitable for outdoor use. Can be applied on PVC coated steel.
- ☀ Suitable for outdoor use. Cannot be applied on PVC coated substrates, film easily changes its color through time.
- W Material will shrink through time. Do not use butt joint method. Use overlap joints and primer when applying multiple W Series panels.
- ✳ Refer to the design pattern on another page (S-20 for SG color chart, S-22 for HG).
- ☐ ! Do not use on three-dimensional surfaces and thermoforming process.

Wall Textures

Key to success:

Understanding the type of wall texture, you have to work with helps you to select the right film for the job.

Determining Type of Texture

Texture has a significant affect on DI-NOC™ film choice, ease of application, adherence and removal.

If the texture is too heavy, the direct application of 3M DI-NOC™ films may not be possible. Use putty and primer to smooth the surface.

Many walls consist of a **substrate** - the supporting structure - with a coating or covering such as paint, varnish, putty, wallpaper or other surface finish. That finish becomes the wall's **application surface**. For other walls, the substrate is also the wall's application surface. For example, brick, concrete block, ceramic tile or laminate may function as both a substrate and the application surface.

Every application surface has some sort of texture. The texture might be as smooth as glass or as rough as heavily textured concrete and everything in between.

Smooth textures. Little or no surface variation. Provides the easiest application since the DI-NOC™ adhesive can make contact with the entire surface.

Unsmooth texture. Have high and low spots, which range from just a little texture (like fine sand paper) to heavy texture (like brick). Extra effort and more time-consuming application techniques may be required to maximize the amount of DI-NOC adhesion to the wall.

- **Medium.** Relatively equal distribution of moderately high and low spots.
- **Heavy.** Irregular and severe high spots and/or low spots.
- **Other.** Brick, concrete block, stucco and tile.

Identifying Wall Composition

Brick. A kiln-dried, hard clay surfacing material, thicker than tile, for interior or exterior walls. Inherently smooth, but may be patterned or textured before firing.

Painted wallboard. Common interior wall surface, primed, painted and thoroughly dried. The texture varies depending on the paint technique used.

We recommend gypsum board finish level five wallboard, which is described in the National Gypsum Construction Guide, 9th Edition, Rev 8/04, page 121. This product has the highest quality finish. A primer and final coating (such as putty) is recommended. When using DI-NOC™ films final coating should be semi-gloss or enamel paint only.

Concrete. A building material made from a mixture of Portland cement, water, fine and coarse particles. Texture can range from smooth to heavy.

CMU (Concrete masonry/concrete block). A usually hollow building block made with concrete. May be painted or unpainted. Texture is usually medium.

Stucco. A cement or plaster mixture that is hand or machine applied to interior or exterior walls. Our example is between smooth and medium texture, although texture can range from smooth to heavy.

Tile. A kiln-dried, thin, hard clay surfacing material for interior or exterior walls. May be glazed or unglazed. Surface is usually smooth.

Vinyl wall covering. A thin to heavy weight vinyl material used to cover interior walls. Texture can range from smooth to heavy. These materials may contain plasticizers that migrate to the surface and can cause premature adhesion failure for a graphic applied over it.

About the Images on the right side of this page

Use the above descriptions and the images on the right side of this page to determine both the texture and wall composition of common interior wall surfaces. These characteristics are important in selecting the right film as well as determining if the wall is suitable for a successful DI-NOC™ application.

Smooth Concrete

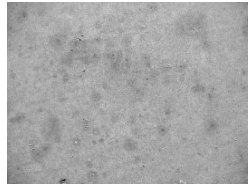

Medium Concrete

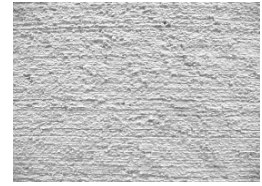

Smooth Vinyl Wallcovering

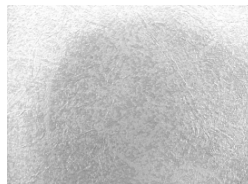

Medium Vinyl Wallcovering



Smooth Painted Wallboard

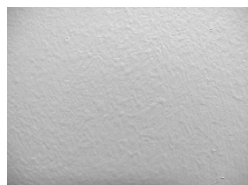

Medium Painted Wallboard

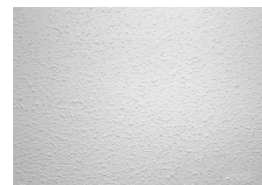

Heavy Concrete

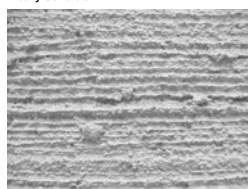

Other - Tile Glazed

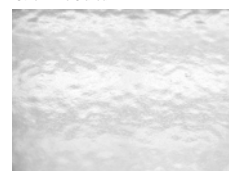

Heavy Vinyl Wallcovering



Other - CMU/Concrete Block Painted and Unpainted

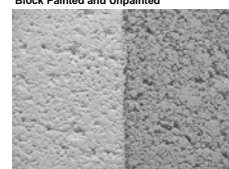

Heavy Painted Wallboard



Other - Brick



Other - Stucco

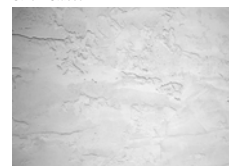

Inspecting and Repairing Walls

Key to success:

Inspecting and repairing walls before you apply the DI-NOC™ films eases installation and helps ensure good removal.

Please refer to DI-NOC™ DVD.

Common Interior Wall Problems

Each of the following problems can contribute to poor DI-NOC™ adhesion and damage during DI-NOC™ removal if the problem is not repaired or considered prior to DI-NOC™ application:

- Too highly textured paint.
- Poor initial paint bond.
- Poorly painted wall edges.
- Patched areas that have not been primed.
- Moisture behind the wallboard, which can cause the DI-NOC™ adhesive to release. Watch for walls that back up to cooling systems, water pipes, overhead windows or water pipes that could drip on the graphic and boarded up windows. These areas are subject to condensation that may not be obvious at the time of installation.
- Dust, dirt or vehicle exhausts contamination on the wall.
- Vinyl wall covering as a substrate: always test the surface for acceptable adhesion characteristics.
- Contamination by other products on the wall that was not properly cleaned.

About Outgassing

As a wall finish dries, it releases certain gases until it is fully dried and cured. Applying a DI-NOC™ film before the finish has cured can result in lifting, bubbles and premature graphic failure.

Air Quality Regulations

State Volatile Organic Compound (VOC) regulations may prohibit the use of certain cleaning solutions or primers. You should check with your State environmental authorities to determine whether use of this solution is restricted or prohibited.

Applying DI-NOC™ to Interior Walls/Floors

Key to success:

Read all instructions before you start: this application may be different from what you have done before.

These instructions are for applying graphics to interior/exterior elevators, walls etc. For any other type of application, please refer to 3M Related Literature, or visit our website at www.scotchprint.com.

Who Can Install DI-NOC™ Films?

A non-professional installer may install poster-size graphics with ease. Larger DI-NOC™ graphics can be more difficult to handle and align, and multi-panel graphics require skill that is acquired only in practice. Therefore, we recommend contacting a professional graphics installer for assistance with larger DI-NOC™ graphics.

Tools and Supplies

- Putty
- Scotch™ Masking Tape
- 3M™ Plastic Applicator PA-1 (Gold*/White*)
- 3M™ Surface Preparation System*
- Cutter for liner
- Ruler (minimum of 1 meter)
- Measuring tape
- 3M™ Air Release Tool 391X
- Band Paper
- Cutting tools, such as a razor blade with a safety holder
- Primer and brush
- Industrial heat gun; must be capable of attaining 260°C to 399°C, or equivalent

*Available from 3M Commercial Graphics Division

Substrate Cleaning and Preparation

Clean the substrate immediately before applying DI-NOC™ films. Dust and other contaminants can collect quickly on the substrate and prevent the film from adhering properly. Use a clean lint-free cloth.

If the substrate has any contaminants e.g. dust, dirt, grease, loose paint, etc., the DI-NOC™ film will not stick to it.

Pay extra attention to cleaning wall edges and corners.

For interior walls where grease and/or oil are present on the substrate: Wash the substrate with

a solution of detergent and lukewarm water. After drying, use 3M™ Surface Preparation System.

For most other surfaces: Wash the substrate with detergent and lukewarm water. Avoid soaps or preparations that contain waxes, oils or lotions. Some window cleaners contain waxes.

Smooth poured concrete walls or concrete block walls may require power washing or hand washing with a stiff brush and a detergent cleaner followed by a clean water rinse to remove grease and/or exhaust contaminants. Allow the surface to dry thoroughly (at least 24 hours) before applying the DI-NOC™.

Wet or Dry Application Method?

Dry application. All DI-NOC™ films must be applied using a dry application method since DI-NOC™ adhesive is Comply™ based.

Wet application. This method is not recommended/warranted for DI-NOC™ application.

Recommended Application Temperature Range

15°C – 38°C preferred

Plan Your Layout

To minimize application problems, which waste time, test your layout by temporarily positioning the graphic on the substrate using masking tape.

Overlap Application

Apply primer to the DI-NOC™ film that will be overlapped. Wait until the Primer is completely dry before applying the next section of film.

Depending on the surface pattern and emboss texture, overlapping may prove to be difficult (e.g. Wiping Wood grain series). Use heat gun and squeegee pressure on edges to adhere the adhesive properly. For assistance, please contact 3M Commercial Graphics Technical Service.

Application Tape

For premask/prespace use 3M™ SCPS-100 application tapes. For electrocut 3M™ SCPS-55 is recommended.

Edge Sealer

If edge sealer is necessary, use 3M™ Scotchcal™ 3950 edge sealer.

Applying a Large Graphic

Center Hinged Method

1. Position the DI-NOC™ graphic, using strips of Scotch™ Masking Tape to hold the graphic to the substrate. Then, apply a strip of masking tape 5.1 cm - 7.5 cm wide, horizontally across the top of the graphic. See Figure 1.
2. Fold half of the DI-NOC™ graphic back over the hinge. Peel off the liner all the way to the tape hinge. Then cut just the liner along the hinge. Discard the liner. See Figure 1.
3. Fold the graphic back onto the substrate.

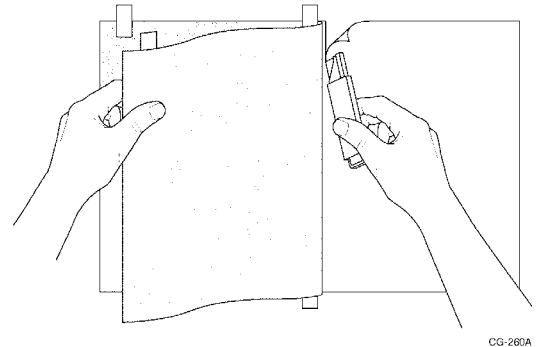

CG-260A

Figure 1. Remove Liner with Center Hinged Method

4. Hold the DI-NOC™ graphic away from the surface with one hand. Allow the adhesive to touch the substrate as pressure is applied during squeegeeing. Squeegee the graphic beginning at the center of the tape hinge and working outward to the closest edge. See Figure 2. Use firm pressure on the plastic applicator and overlap the strokes.
5. Remove the tape.
6. Apply the other half of the graphic in the same manner.
7. Complete the application by re-squeegeeing the edges.

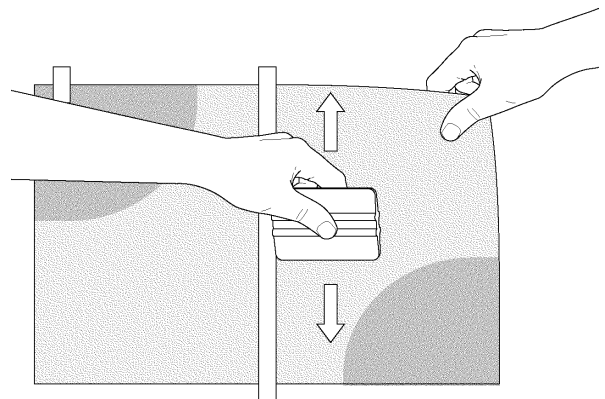

CG-261A

Figure 2. Squeegee a Center Hinged Graphic

Butt Joint Application Method

Whenever two or more panels of the same color of DI-NOC™ film are seamed together they should be matched to assure uniform daytime color and transmitted night appearance.

Material from a single roll or lot must be used on a single marking or sign for identical color matching.

- Butt joint is used only when visibility is important
- Prime 5 cm of the substrate on the butt joint area to avoid any shrinkage on butt joint area over years
- Leave 5 cm of liner on panel 1
- Apply panel 1
- Apply panel 2 overlapping panel 1 by 3 – 5 cm
- Use a straight edge to cut through both panels on the overlap area
- Remove liner and excess film
- Apply film to form a butt joint

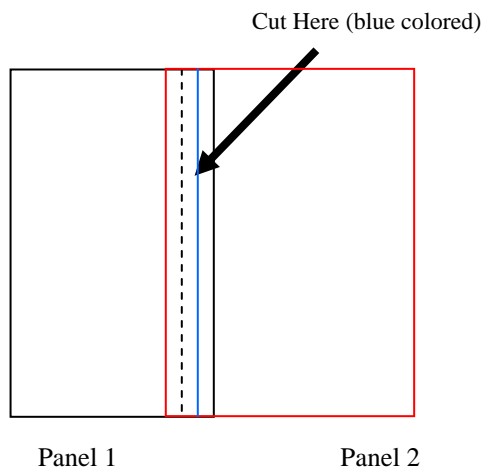

Note: Butt joint is not recommended for three-dimensional surfaces and curved areas. Use overlap for it.

Trimming Requirements

Certain areas of your graphic applications are more subject to damage than others from people or equipment rubbing against the edges. This includes areas around doors, openings such as vents, outside corners of walls and inside corners. To reduce the risk of damage and lifting, trim the DI-NOC™ from the edge. After application, re-squeegee all edges of the graphic to help ensure good edge adhesion.

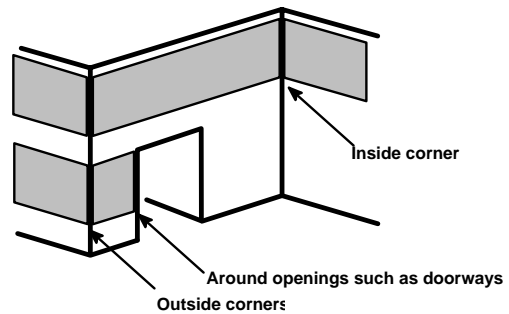

Finishing the Graphic Edges

Usually, the area with the least adhesive bond is the outer few cm of the graphic. Always re-squeegee the edges in small circular movements before you consider the job done. Use a heat gun at 70°C. Always grasp the film as far into graphic as possible without wrinkling the film to avoid transferring body oil and dirt to the adhesive, which can cause adhesion problems. To avoid the problem calculate 5 – 10 cm more material on all edges.

DI-NOC™ Application Procedure Three-Dimensional Curved Surface

- D When applying to a non-circular 3D surface, apply firstly at the corners, then along the straight edges in the sequence: a, then b & c, then d & e, etc.

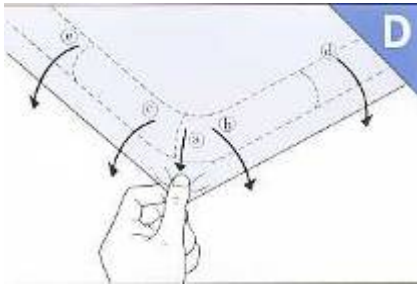

- E Prime the rear surface (approx. 5 cm in from the edge) and extend the DI-NOC™ application 2 – 5 cm onto the rear surface. This secures the product and prevents it from shrinking.

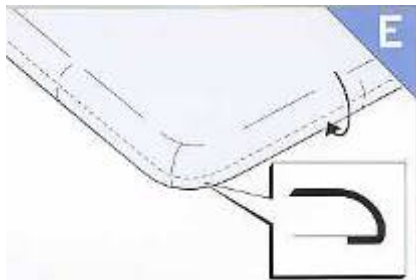

- F Trim off any excess DI-NOC™ on the rear surface and apply a tab/strip of DI-NOC™ to the cut edge (in particular, the corners), to further stabilize the application and prevent shrinkage.

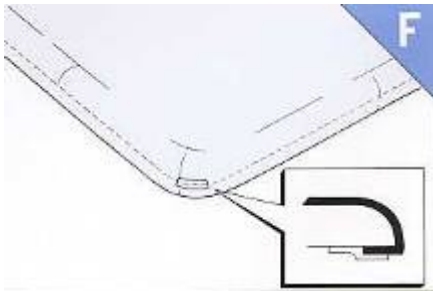

Installation explanation

Apply film to the protruding metal corner extrusion

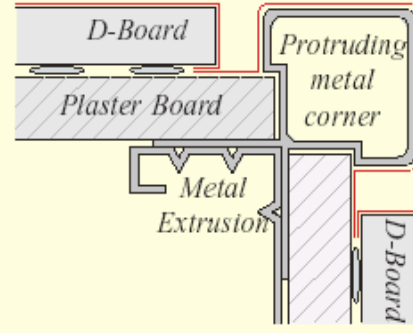

Installation Example

Screw the decorative molding to hold the film down. The decorative molding is a feature and also hides the film seams.

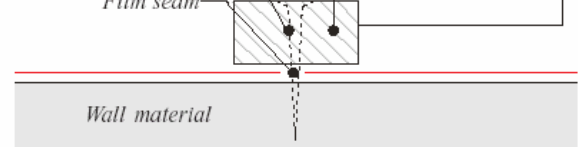

Ceiling Application

Installation Details

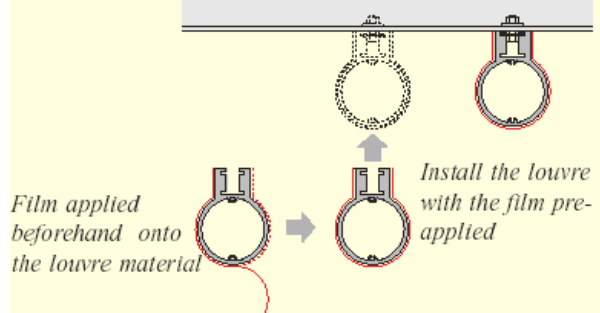

Installation Details

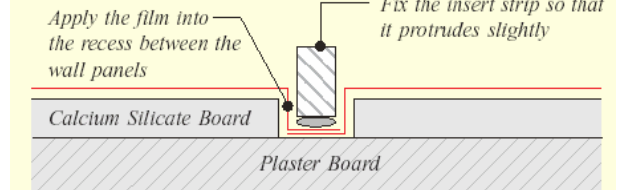

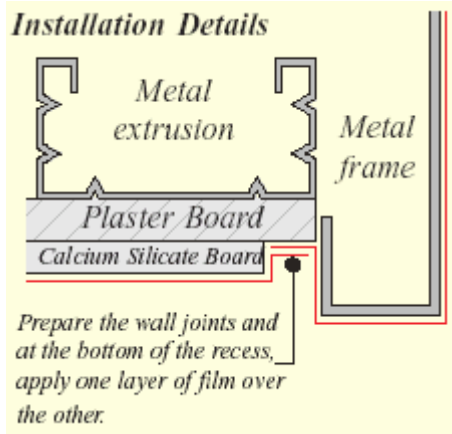

Wall Panelling Application

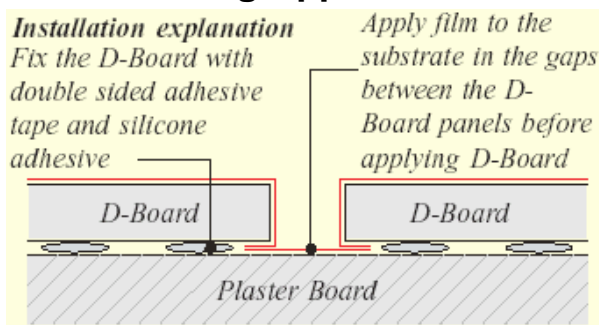

Bathroom Application

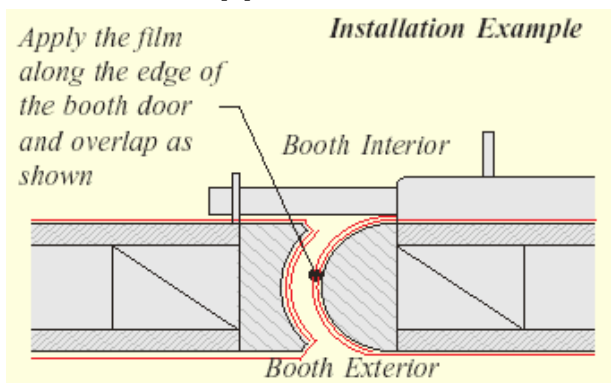

Surface Patterns and Emboss Textures

When cutting DI-NOC™ films or applying panels of the same design side by side, adjoining panels may contrast significantly in color. Make sure that material for adjoining panels is applied in the same roll direction and from the same production lot. In addition, there are very subtle changes in grain pattern in the embossed surfaces of the films. Check on the grain direction before applying adjoining panels to minimize any color shift or gloss change between the panels.

Other Application Issues

1. Avoid applying the materials in locations that face direct sunlight and are surrounded by glass. Increased temperature may cause damage to the glass.
2. You may occasionally see a splice in a roll.
3. Please consider the color of the application surface before applying DI-NOC™ films. Highly colored substrates can cause a slight color shift in some DI-NOC™ films. A test application should be performed and the result approved by the customer, if the films must be applied to a highly colored surface.
4. Counter top and table top application: If abrasion is a problem use DI-NOC™ DPF200 laminate or DI-NOC™ CCM Series (non standard).

Cleaning DI-NOC™ Film

1. Use commercially available synthetic detergent. Avoid using organic solvents or strong detergents that are either highly alkaline (pH>11) or acid (pH<3). Check with us for 3M Cleaners that are compatible with DI-NOC™.
2. Use a soft cloth or cleaning sponge. Do not use sponges or cleaning cloths that contain abrasive materials.
3. Moisture that has penetrated wallboard will destroy the application surface when graphics are removed. Remember that, especially in remodeling jobs, wallboard may have been placed over windows, cooling pipes, etc., that may produce moisture that is transferred to the wallboard.

Removal of DI-NOC™ Film

DI-NOC™ films are not designed with removal in mind, as the combination of film adhesive and primer ensure a very high bond to most surfaces. We recommend applying new material on top of existing DI-NOC™, instead of removal. However, if DI-NOC™ must be removed, the following method can be attempted.

1. Make cuts about 20 cm apart in the DI-NOC™ film, making sure not to damage the substrate.
2. Use a hair drier to warm at 80°C to soften the DI-NOC™ film.

3. Remove the strips of film.
4. If adhesive remains on the substrate, remove it using 3M™ Adhesive Remover System R-231, or similar solvent.

Note: Test that the solvent will not damage the substrate before beginning removal.

DI-NOC™ Specifications

Construction: polyvinyl chloride film with permanent adhesive

Roll size: 1220 mm x 50 m (D, FN, ME, VM Series 1220 mm x 25 m) (HM-10F – 960 mm x 50 m)

Application Environment: Minimum application temperature 12°C

Recommended Application Temperature: 16°C – 38°C (20°C – 25°C preferred)

D. Storage Conditions

Store film in a clean, dry environment, free from direct sunlight and at an ambient temperature below 38°C. The combined shelf life as processed and unprocessed film cannot exceed 1 year from the date you receive the film. However, the film must be used within 1 year of purchase.

Warranty

The information contained and techniques described herein are believed to be reliable, but 3M makes no warranties, express or implied, including but not limited to any implied warranty of merchantability or fitness for a particular purpose. 3M shall not be liable for any loss or damages, whether direct, indirect, special, incidental or consequential, in any way related to the techniques or information described herein.

3M Related Literature

Before starting any job, be sure you have the most recent product and instruction bulletins.

The following bulletins provide the information you need to properly use the 3M products that may be used in your graphic. You can find these bulletins on our Web site at www.scotchprint.com.

There is a DVD available to demonstrate the application of DI-NOC™ products. Please contact your local 3M Technical Service person.

For Further Assistance

For help on specific questions relating to 3M Commercial Graphics products, please contact your local 3M Technical Service person or contact:

3M Deutschland GmbH
Display & Graphics Laboratory
Carl-Schurz-Straße 1
D-41453 Neuss
Germany
Phone: +49(0) 2131 14 3500
Fax: +49(0) 2131 14 2377
Internet: www.mmm.com/yy (your country code)

The use of trademark signs and brand names in this bulletin is based upon US standards. These standards may vary from country to country outside the USA.